

Installation Methods

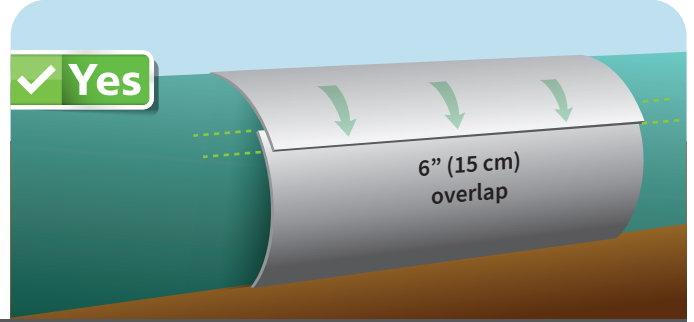

Position: 6" (15 cm) overlap pointing downward

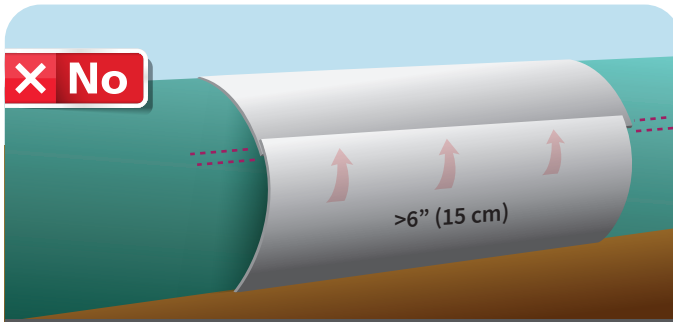
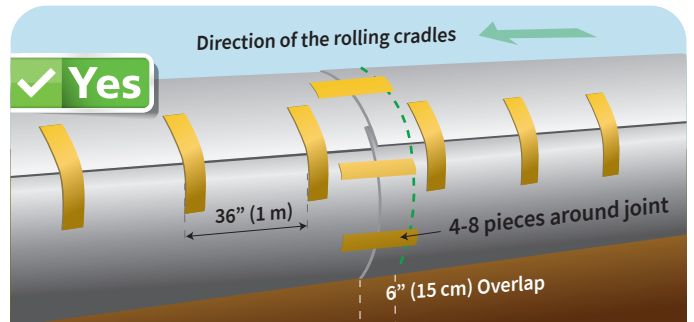
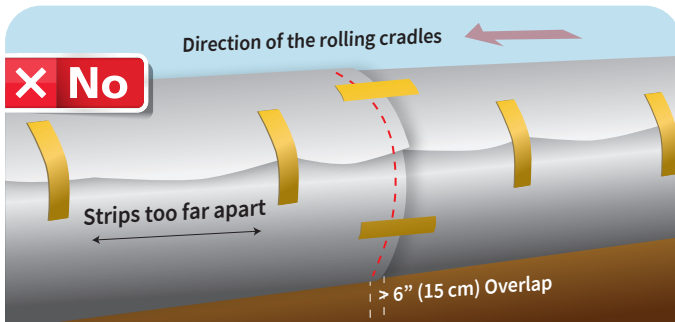

Method 1: QuikStrips™ are 36" (1 m) apart

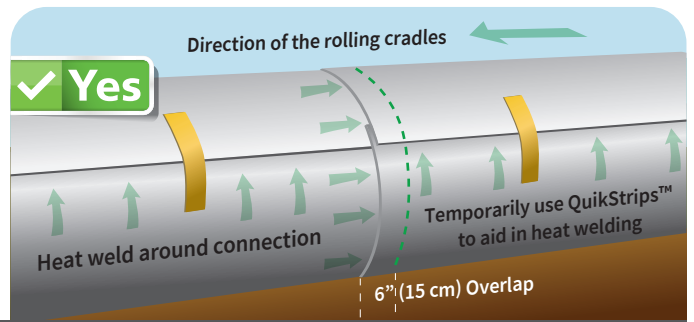
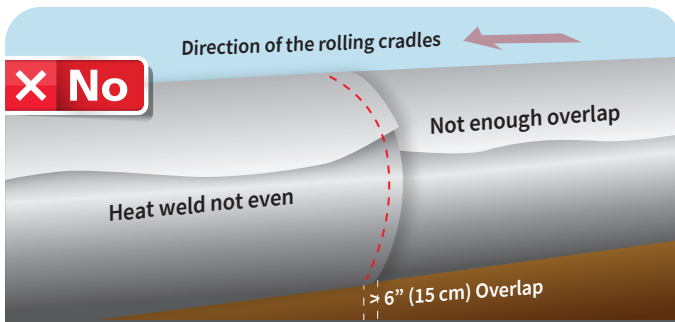

Method 2: Heat weld to seal

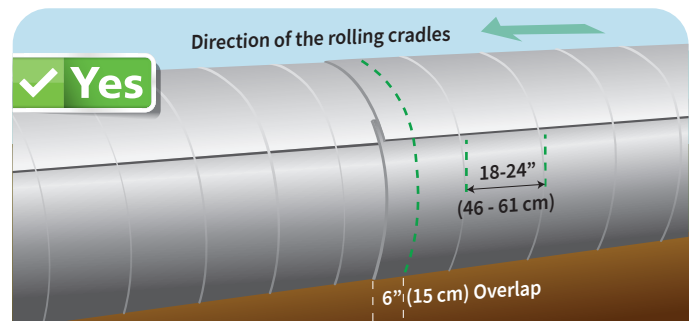
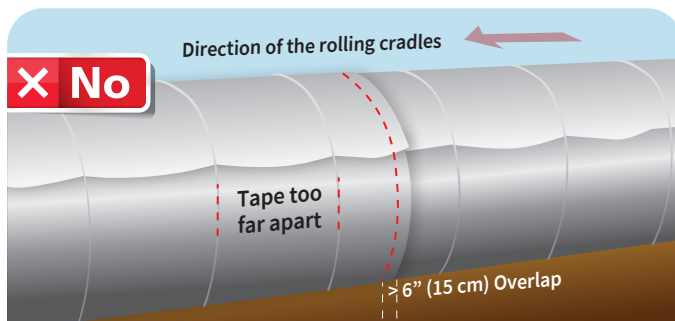

Method 3: Butyl or filament tape, 18-24" (46-61 cm)