



PipeSak® Pipeline Protection

Technical Notes

PipeDefender® Dimensional Data

PipeDefender® Panel Dimensions	PD24/36/48 Full Panel	PD30/42 Partial Panel A	PD20 Partial Panel B
Weight	23 lbs (10.4 kg)	12.4 lbs (5.6 kg)	16 lbs (7.3 kg)
Width (A)	41.5" (105.4 cm)	23.4" (59.4 cm)	28.9" (73.4 cm)
Overall Length (B)	50" (127 cm)	50" (127 cm)	50" (127 cm)
Installed Length (C)	48" (121.9 cm)	48" (121.9 cm)	48" (121.9 cm)
Height (D)	2.25" (5.7 cm)	2.25" (5.7 cm)	2.25" (5.7 cm)

Note: For NPS 20, 30, and 42 reduced panel sizes will be provided to fully encircle pipeline.

Panels needed for:	NPS20	NPS24	NPS30	NPS36	NPS42	NPS48
PD24 / PD36 / PD48	1	2	2	3	3	4
PD30/42 (Partial Panel A)	0	0	1	0	1	0
PD20 (Partial Panel B)	1	0	0	0	0	0

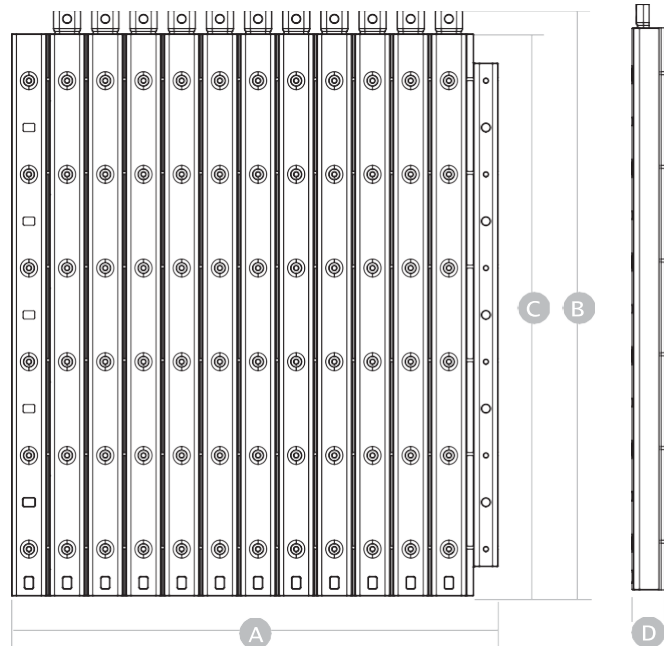
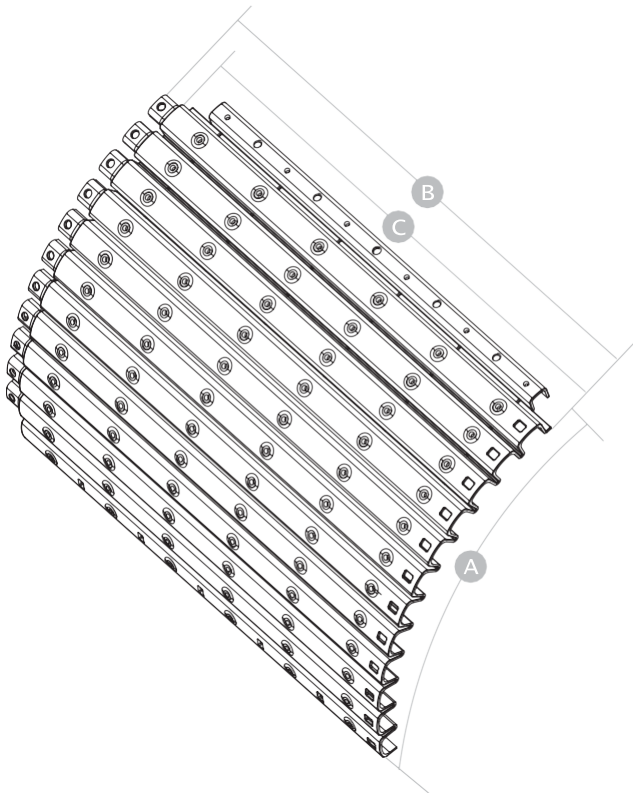



PipeSak® Pipeline Protection

Technical Notes

PipeDefender® SD Dimensional Data

PipeDefender® SD Panel Dimensions	PD12 Full Panel	PD16 Full Panel
Weight	15lbs (6.8 kg)	19 lbs (8.6 kg)
Width (A)	45" (114.3 cm)	56.67" (144 cm)
Overall Length (B)	37.5" (95.3 cm)	37.5" (95.1 cm)
Installed Length (C)	36" (91.4 cm)	36" (91.44 cm)
Height (D)	0.94" (2.4 cm)	0.94" (2.4 cm)

Note: For NPS 4, 6, 8, and 10 pipelines, PD12 panels need to be trimmed to width listed below

Trim panels for:	NPS4	NPS6	NPS8	NPS 10
Cut Width (E)	18.75" (47.6)	26" (66 cm)	32" (81.3 cm)	37.75" (95.9 cm)

